



## INTRODUCING GENESIS

**Same Quality for Less Money!**

**FURNITURE BOARD CONSTRUCTION FEATURING  
SOFT CLOSE DOORS AND DRAWERS**



Bella Plus  
White



Park Place  
White



Bella Plus  
Smoked  
Cashew



Park Place  
Smoked  
Cashew

Solid wood, dovetail, 1/2" plywood bottom and soft close drawer boxes

Cabinet sides, top & bottom are made with 1/2" select furniture board with natural finish

Adjustable shelves are made with 3/4" select furniture board with natural finish and matching front edge banding

Doors & face frames are complete with mortise and tenon solid wood stiles & rails

Sherwin Williams finish

**Williams  
Distributing**

658 Richmond NW  
Grand Rapids, MI 49504  
1-800-748-0503  
[www.wmsdist.com](http://www.wmsdist.com)

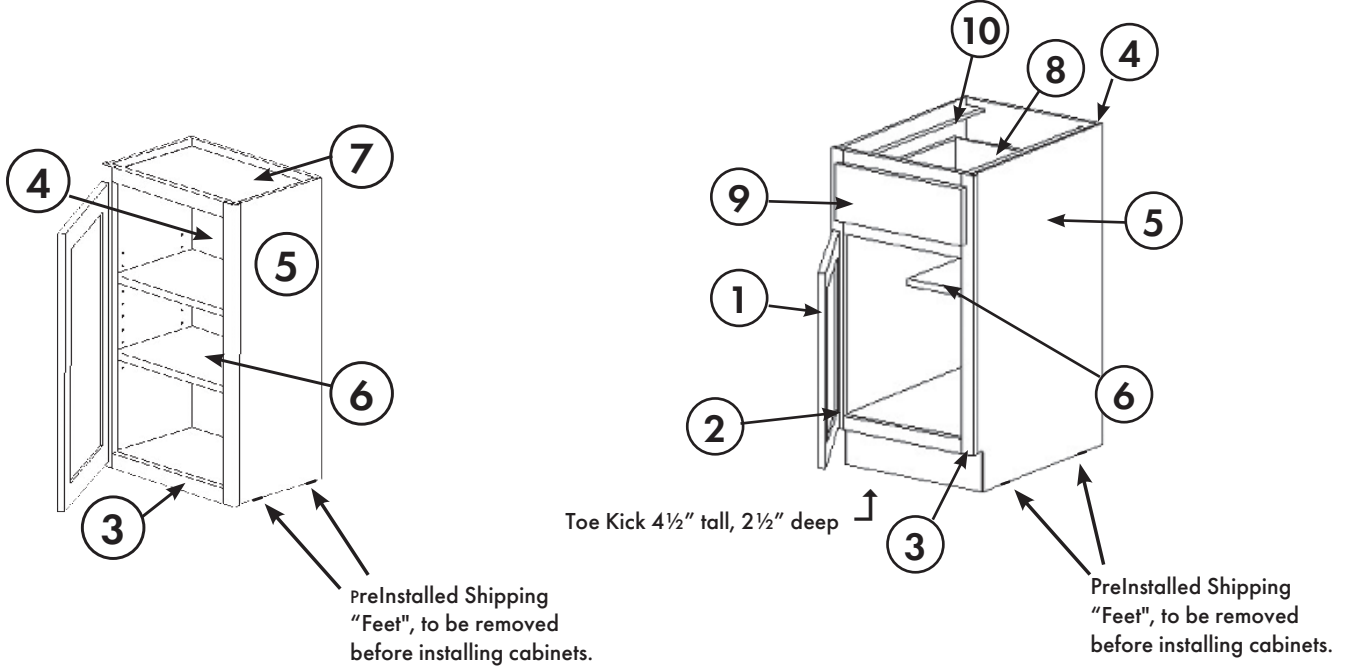

## 1. Doors

- Mortise and tenon solid wood stiles and rails.
- Painted doors mortise and tenon made from MDF.

## 2. Hinges

- Soft-Close concealed hinge with 107° opening.

## 3. Face Frame

- ¾" x 1½" solid wood mortise and tenon.
- Comes pre-drilled for hinges Left and Right

## 4. Backs

- ½" select birch veneer plywood.
- Ultraviolet clear finish.

## 5. Side Panels

- ½" maple laminate furniture board.
- Ultraviolet clear finish inside cabinet
- Exterior matches the frame and door.

## 6. Adjustable Shelving

- ¾" maple laminate furniture board with matching front edge banding.
- Base cabinet shelf depth 15⅝".

## 7. Tops and Bottoms

- ½" maple laminate furniture board.
- Ultraviolet clear finish.

## 8. Drawer Boxes

- Hybrid dovetail solid maple.
- ½" plywood bottoms
- Undermount soft close full extension drawer slides.

## 9. Drawer Box Interior Depth

- 3 ⅜" interior top drawer functional depth.
- Deeper than most competitors.

## 10. Panel Beams

- ½" thick x 2 ¼" furniture board panel beams.

Contact your Williams Rep for more information!